



## PS Series Best Practices

# Deploying Microsoft® Multipath I/O in an iSCSI SAN

---

### **Abstract**

This Technical Report describes how to use Microsoft multipath I/O (MPIO) on Windows Server™ 2003 servers for highly available access to disk storage. PS Series storage delivers a scalable and fault-tolerant iSCSI SAN solution that increases data and application availability and is easy to configure and manage.



Copyright © 2005 EqualLogic, Inc.

October 2005

EqualLogic is a registered trademark of EqualLogic, Inc.

All trademarks and registered trademarks mentioned herein are the property of their respective owners.

Possession, use, or copying of the documentation or the software described in this publication is authorized only under the license agreement specified herein.

EqualLogic, Inc. will not be held liable for technical or editorial errors or omissions contained herein. The information in this document is subject to change.

PS Series Firmware Version 2.2.3 or higher

# Table of Contents

---

Revision Information .....	iv
Introduction to Multipath I/O .....	1
Delivering Highly-Available Access to Data .....	1
Microsoft Multipath I/O Solution .....	2
Basic Setup Steps.....	4
Setting Up the iSCSI SAN.....	4
Creating and Managing a PS Series Group.....	4
Configuring Multiple Network Interfaces on an Array .....	5
Creating PS Series Volumes .....	6
Restricting Access to Volumes .....	7
Setting Up the Windows Server.....	9
Windows Server Requirements .....	9
Installing the Microsoft iSCSI Software Initiator .....	10
Uninstalling the Microsoft iSCSI Software Initiator .....	13
Setting Up Multipathing .....	13
Configuring Multiple Paths to a Target .....	13
Modifying the Load Balancing Policy.....	19
Displaying Path Information.....	22
Testing Multiple Paths to a Target.....	23
Summary.....	23
PS Series Documentation and Customer Support.....	24

## Revision Information

---

The following table describes the revision history of this Technical Report.

Technical Report Revision	Date	Change
1.0	October 19, 2005	Initial draft

The following table reflects the software and hardware revisions used for the preparation of this Technical Report.

Vendor	Product / Model	Software Revision
Microsoft®	Windows Server™ 2003 Enterprise Edition	Service Pack 1 KB891957
Microsoft	iSCSI Software Initiator	Version 2.0
EqualLogic®	PS Series Firmware	Version 2.2.3
QLogic™	QLA4010 iSCSI HBA	BIOS: 1.11 Firmware: 03.00.00.04
QLogic	SANsurfer Manager	4.01.00
QLogic	iSCSI Firmware	03.00.00.04

## Introduction to Multipath I/O

---

To support the needs of users and customers, businesses must ensure that applications run continuously and reliably, with the performance needed to meet workload demands. Typical solutions involve redundant storage hardware and RAID technology. However, when using a storage area network (SAN), the path between servers and storage is a crucial element that also must be protected from failure.

You can use Microsoft multipath I/O (MPIO) to configure redundant network paths between Windows servers and highly-available, scalable PS Series storage arrays from EqualLogic. This is accomplished by having more than one physical path between the server and each storage array in the PS Series group.

Multipath I/O enables the server to detect network disruptions and fail over I/O to a functioning path in the event of a failure. It also provides robust load balancing capabilities for a reliable, high-performance I/O path between Windows servers and PS Series storage.

Multipath I/O can be implemented using standard network interfaces (NICs) with the Microsoft iSCSI Software Initiator Version 2.0. Alternately, you can use a third-party iSCSI host bus adapter (HBA) and the service portion of the Microsoft iSCSI Software Initiator. Using an iSCSI HBA to offload iSCSI TCP from the operating system can improve performance.

## Delivering Highly-Available Access to Data

---

High availability refers to the ability of a system or configuration to survive a failure in each vital component. Thus, a comprehensive, highly-available computing environment can have no single point of failure. All hardware and software components—from the operating system to the network hardware to the storage—must be redundant, and failover mechanisms must provide rapid and automatic recovery.

A comprehensive high-availability solution could include the following:

- **Highly available disk storage.** RAID (redundant array of independent disks) technology provides automatic failover in the event of a disk failure, in addition to performance enhancements. A disk array must support redundant network connections for MPIO.

There are many RAID solutions available today, with a variety of capabilities and costs. However, the most common direct-attached storage (DAS) is burdened by capacity and management constraints, while Fibre Channel SANs remain complex and costly.

In contrast, PS Series storage arrays, enable you to set up an affordable iSCSI SAN in minutes, with on-demand scalability, automatic RAID configuration and disk sparing, point-in-time data replication, redundant hardware, and multiple network interfaces. The only server requirement is an industry-standard iSCSI initiator.

- **Multipath access to storage.** Storage that is directly attached to a server (DAS) is becoming more and more a relic of the past. Now, servers often access a SAN through long-distance network connections that are likely to involve complex cabling and switches. Because these connections are vulnerable to failure, multipathing is used to ensure that there is always a viable path between a server and data.

There are a variety of multipathing solutions. Some provide the ability to detect a path failure and automatically fail over to a functioning path. Ideally, the interruption should be transparent to applications and servers, with only a short interruption in service. Choosing a path based on performance statistics is also desirable.

To be effective, a multipathing solution must seamlessly and efficiently interact with the operating system, network components, and storage configuration. This can present difficulties for third-party software, which may not have detailed knowledge of the storage subsystem and the operating system on which it is running. Multipathing solutions integrated with the operating system can resolve some interoperability issues, but they may lack in-depth knowledge of the storage subsystem.

Microsoft multipath I/O, in conjunction with scalable and reliable PS Series storage, provides an ideal solution, effectively utilizing the capabilities of both the operating system and the storage subsystem. The following figure shows an example of a highly-available computing environment with redundant physical paths from a server to a PS Series storage array.

**Figure 1: Highly-Available Computing Environment**

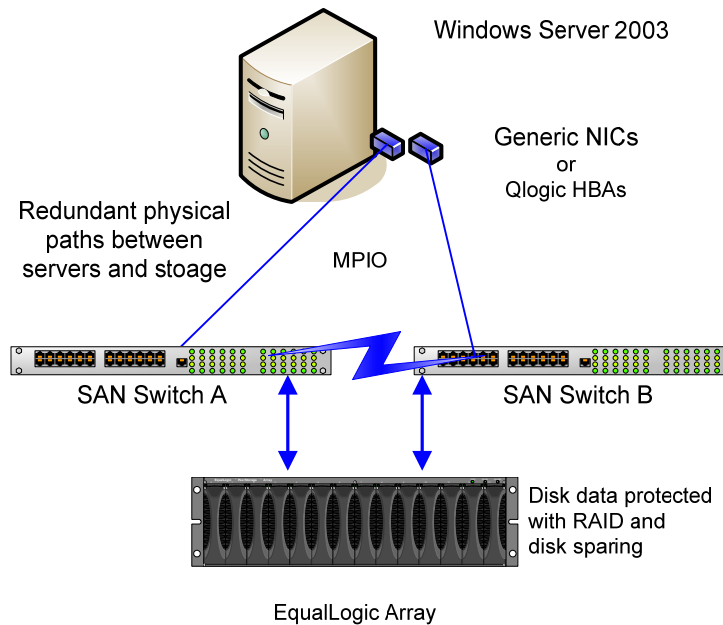

## Microsoft Multipath I/O Solution

Microsoft provides multipathing software in an MPIO driver package, which is fully integrated with the operating system. To access iSCSI targets in a PS Series SAN from a Windows server, with or without multipathing, you need the Microsoft iSCSI Software Initiator Version 2.0.

Microsoft multipath I/O provides:

- Increased server bandwidth and volume bandwidth.
- Reduced network latency.
- Automatic failure detection and failover.
- Automatic load balancing.

- Support for multiple connections from a server to a single storage “device” (iSCSI target).
- Easy installation.
- Supports multiple MPIO sessions to a target. You are only limited by the number of NICs or HBAs installed in the server.

The Microsoft iSCSI Software Initiator control panel includes an MPIO tab that enables you to configure a set of paths to a target (for example, a PS Series group volume). The iSCSICLI command line tool can be used for scripting and completely exposes all functionality available by the Microsoft iSCSI Software Initiator service.

Each path uses different NICs or iSCSI HBAs and, ideally, a separate network infrastructure (cables, switches, routers, etc). Multiple network connections to each storage array are also needed. If a fatal path failure occurs, the problem is quickly detected, and I/O transparently fails over to a functioning path. MPIO can recognize and correctly handle a variety of network and device errors and timeout conditions.

The following figure shows a multipathing solution using a Windows server with redundant network connections to a single PS Series storage array.

**Figure 2: Windows Server 2003 with Multipath I/O**

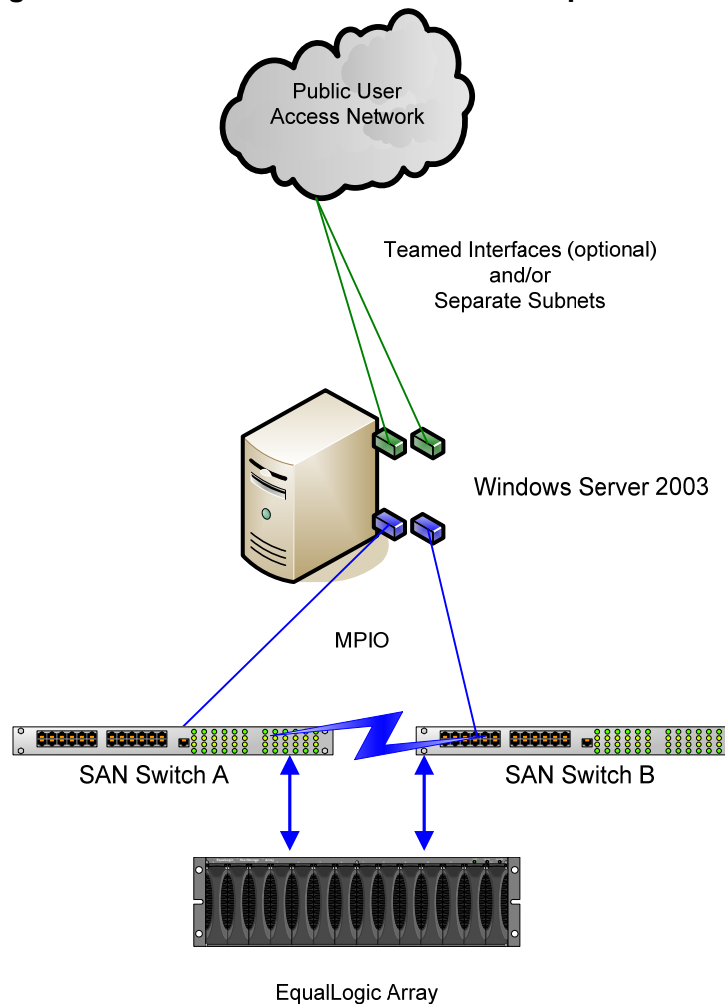

## Basic Setup Steps

---

Follow these steps to configure multipath I/O between a Windows server and PS Series storage.

1. **Set up a PS Series group and create one or more volumes.** Be sure to configure multiple network interfaces on each group member.

Also, be sure to create one or more access control records for each volume to allow the server access to the volume. In addition, reserve snapshot space for each volume if you want to create volume snapshots or use Auto-Snapshot Manager for VSS backups.

For more information, see *Setting Up the iSCSI SAN*.

2. **Optimize the SAN network for performance.** See the Technical Report *Network Connection and Performance Guidelines* on the EqualLogic Customer Support for requirements and best practices.
3. **Set up the Windows server.** Be sure it meets the requirements described in *Windows Server Requirements*. The server must have an iSCSI initiator installed and at least two NICs or iSCSI HBAs configured to handle iSCSI traffic.
4. **Configure multiple paths from the server to the PS Series volumes.** Be sure to establish a persistent connection to the volume and bind the volume so it is available when needed. See *Configuring Multiple Paths to a Target* for more information.
5. **Optionally, change the load balancing policy for the redundant paths.** See *Modifying the Load Balancing Policy* for more information.
6. **Check the multipath configuration.** See *Displaying Path Information* for more information.
7. **Verify that the network connection will fail over.** See *Testing Multiple Paths to a Target* for more information.

## Setting Up the iSCSI SAN

---

The following sections describe how to create a PS Series group, configure multiple network interfaces on an array, create volumes, and restrict access to the volumes.

### Creating and Managing a PS Series Group

---

For detailed information about setting up PS Series storage array hardware and getting started with a group, see the PS Series *QuickStart*. The *Group Administration* manual describes detailed information about volume setup and advanced group management using the graphical user interface (GUI). See the *CLI Reference* manual for information about using the command line interface (CLI) to manage a group and individual arrays. PS Series documentation is available on the EqualLogic Customer Support web site.

Once the group is set up, you can configure multiple network interfaces on each group member, create volumes, and then configure multipath access from the server to the volumes.

Use the Group Manager GUI or CLI to manage a group. Access the GUI from a web browser by connecting to the group IP address. Access the CLI from a telnet or ssh connection to the group IP address or use a serial connection to a group member. Once connected to the group, log in to an administration account such as `grpadmin`.

For example, when you start the GUI, the Group Summary windows appears. Click and expand items in the far left panel of the GUI for detailed information about group components. Relevant asks are shown in the Activities panel.

**Figure 3: Group Manager – Group Summary**

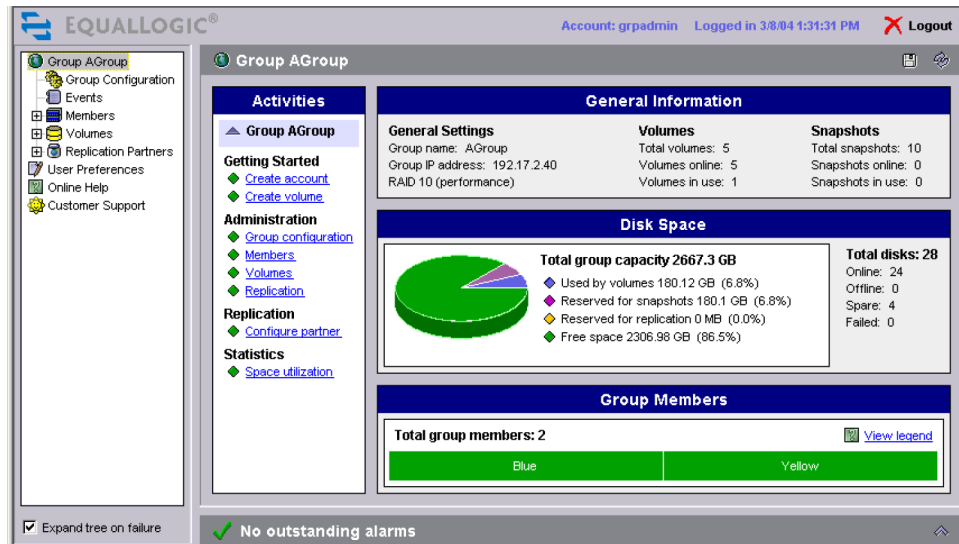

## Configuring Multiple Network Interfaces on an Array

You must configure at least two network interfaces on each PS Series group member in order to configure multipath I/O. A PS Series storage array includes two control modules (CM0 and CM1). Only one control module is active (actively serving I/O) at one time. The secondary control module mirrors cache data from the active control module.

Each control module has three network interface ports, labeled `eth0`, `eth1`, and `eth2`. A dual control module array provides three pairs of network interface ports; only one port in a pair is used for I/O at one time. The `eth0` and `eth1` network interface port pairs are redundant (that is, the active control module can access both ports, regardless of which control module is active). The `eth2` network interface port pair is not redundant (that is, each control module can only access its own port).

To ensure multiple network paths to an array, connect a redundant network interface on one control module (for example, `eth0` on CM0) to one network switch. Then, connect a redundant network interface on the other control module (for example, `eth1` on CM1) to a different switch. For the best performance and highest availability, also connect cables to both `eth2` ports.

**Figure 4: Storage Array Network Connections**

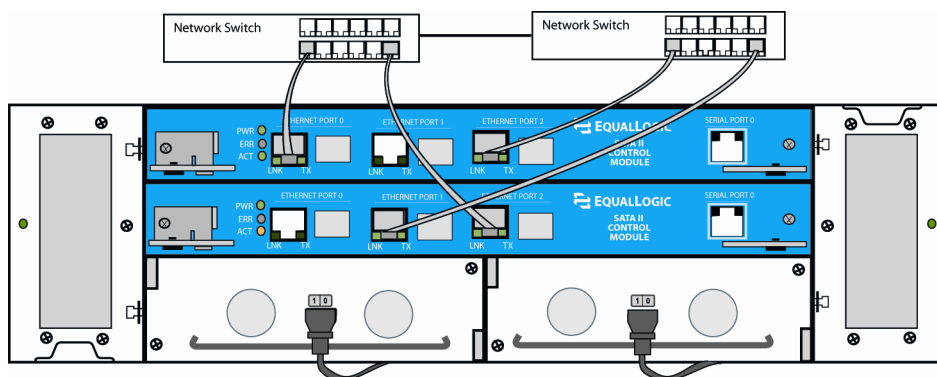

After connecting the network cables, use the Group Manager GUI or CLI to assign an IP address and subnet mask to the network interface. For example, to use the GUI, expand `Members` in the far left panel and select the member name. Click the `Network` tab to display the Member Network window. Select the network interface you want to configure and then click `Modify properties` in the Activities panel.

In the Modify Network Interface Properties dialog box, enter an IP address and subnet mask (netmask), enable the interface, and then click `OK`.

**Figure 5: Group Manager – Modify Network Interface Properties**

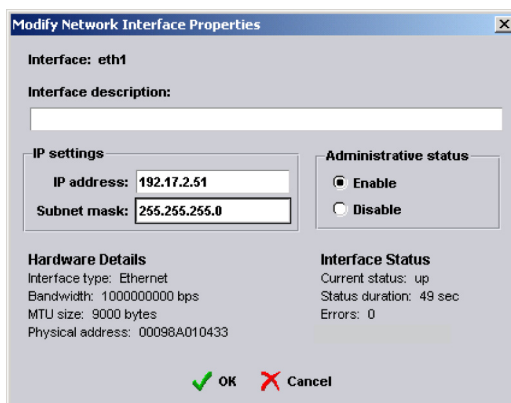

## Creating PS Series Volumes

To use the storage space in a PS Series group, you must create volumes. In addition, to ensure proper security and data integrity, for each volume, create one or more access control records to allow only authorized servers access to the volume. Also, reserve snapshot space if you want to create volume snapshots or use Auto-Snapshot Manager.

You can use the Group Manager GUI or CLI to create volumes. For example, to use the GUI, click `Create Volume` in the Group Summary window. In the Create Volume dialog box, enter a volume name and the volume size. Optionally, reserve snapshot space for the volume. The Space Utilization table shows the current group capacity and the capacity with the new volume.

**Figure 6: Group Manager – Create Volume**



Click **Next** to display the dialog box that enables you to set up an access control record for the volume, as described in *Restricting Access to Volumes*. Note that you can create and modify access control records for a volume at any time.

After you specify the access control information, click **Next**, confirm the volume configuration, and then click **Finish** to create the volume. The volume should appear when you expand **Volumes** in the far left panel of the GUI. Select the volume name to display volume details.

Once you create a volume, an iSCSI target name is automatically generated for the volume. Servers connect to the volume through the group IP address and the target name.

## **Restricting Access to Volumes**

Access control records are used to restrict host access to volume data in a PS Series group. A group volume and its snapshots share a list of access control records (sometimes called the access control list). You can configure a record to apply to the volume, its snapshots, or both, as needed.

When you create a volume with the GUI or CLI, you can create an access control record at that time. You can also create and modify access control records at any time.

For example, in the GUI, expand **Volumes** in the far left panel and select the volume name. Click the **Access** tab in the window that appears, and then either click **Add** or select an existing record and click **Modify**. If you click **Modify**, the **Modify Access Control Record** dialog box appears.

In each access control record, you can specify an IP address, iSCSI initiator name, or CHAP user name (or any combination). A server must match *all* the requirements in *one* record in order to access the volume or snapshot.

You can also specify whether the record applies to the volume, the volume snapshots, or both.

**Figure 7: Group Manager – Modify Access Control Record**

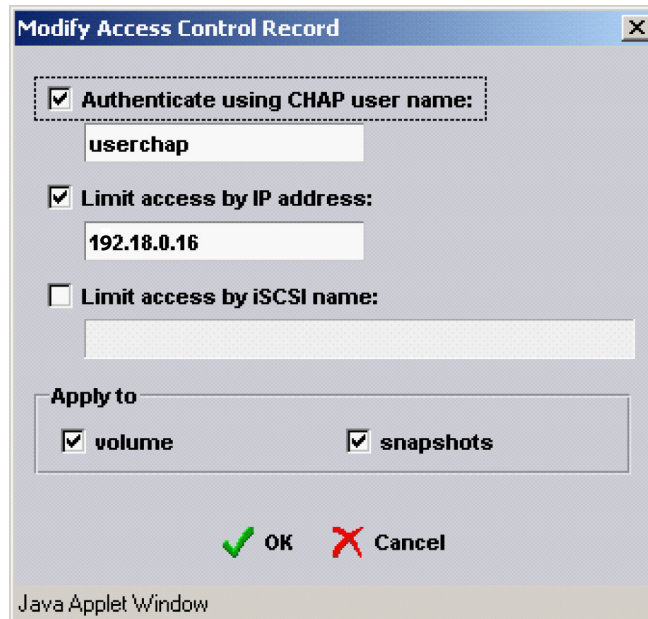

The most secure way to control access to your volumes is to use a combination of IP address and CHAP, as shown in the figure above. For example, if a record includes both an IP address and a CHAP user name, a server must present the IP address *and* supply the CHAP user name and its associated password (using the iSCSI initiator) in order to match the record. Note that, if only a CHAP user name is specified in a record, initiators that support discovery will unsuccessfully try to connect to the volume, increasing event log activity.

**Notes:** If you use IP addresses or iSCSI initiator names to restrict access, create an access control record for each IP address or initiator name presented by the server. For example, in a multipath configuration, a server may have two NICs that are handling iSCSI traffic to a target. In this case, you can create two records, one with the IP address assigned to one NIC and the other with the IP address assigned to the other NIC. This ensures that the server can access the volume, regardless of which NIC is used for the connection.

To use CHAP to restrict host access to volumes, you must configure CHAP in the group, as described in the PS Series *Group Administration* manual.

You can allow unrestricted access to a volume (*only* recommended for a test volume) by specifying 0.0.0.0 for an IP address and not other credentials

Once you specify the access control information, click **OK** to create the record.

The record should appear in the Group Manager Volume Access window, as shown below.

**Figure 8: Group Manager – Volume Access**

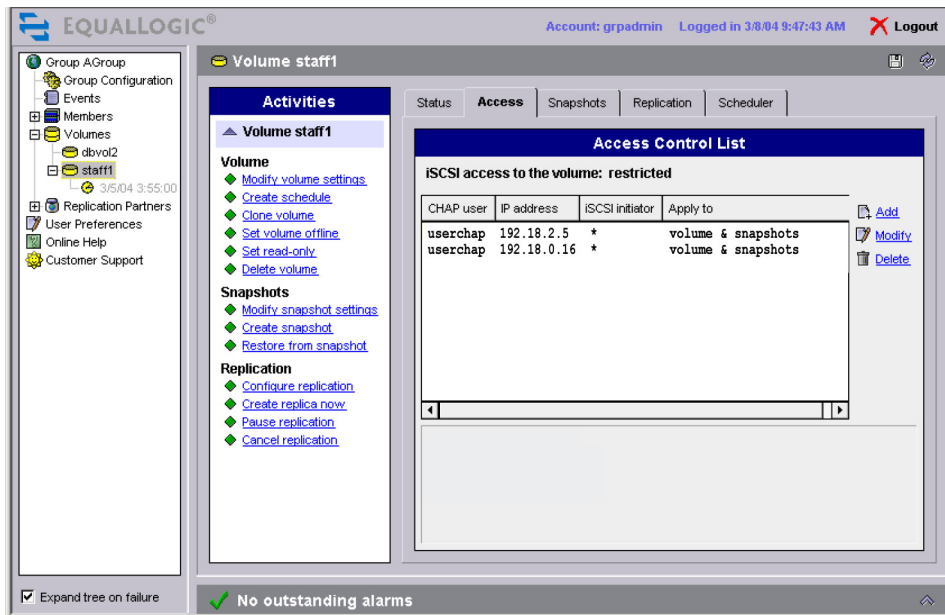

## Setting Up the Windows Server

The following sections describe how to prepare the Windows server for multipath access to PS Series storage, including server requirements and how to install the Microsoft iSCSI Software Initiator.

### Windows Server Requirements

The Windows server must meet the following requirements and restrictions:

- Microsoft Windows Server 2003 with Service Pack 1.
- Industry-standard iSCSI initiator. You can use *one* of the following solutions:
  - Microsoft iSCSI Software Initiator Version 2.0 with at least two Gigabit NICs. You can also use NICs with a TCP offload engine (TOE).
  - At least two QLogic QLA4010 iSCSI initiator HBAs with the 3.0.0.4 firmware *plus* the service portion of the Microsoft iSCSI Software Initiator Version 2.0. In addition, you need the following:
    - BIOS 1.11
    - SANsurfer Version 4.01.00
    - STOR miniport driver 2.1.0.8 (Do *not* install any of the STORport-related hotfixes because Windows Server Service Pack 1 supersedes them.)

See *Installing the Microsoft iSCSI Software Initiator* for information about installing the Microsoft iSCSI Software Initiator.

If you are using a QLogic iSCSI HBA, see *Setting up iSCSI Multi-Path I/O (MPIO) on Windows 2003 with QLA4010 HBAs* for installation information:

[http://www.qlogic.com/cgi-bin/faq\\_display.pl?faq=kb/KB14322.html](http://www.qlogic.com/cgi-bin/faq_display.pl?faq=kb/KB14322.html)

- Each network interface must be assigned an IP address and connected to the network. The Microsoft iSCSI Software Initiator requires that network interfaces be assigned *static* IP addresses.
- Do not configure devices for multipathing if they have different network speeds.

---

## Installing the Microsoft iSCSI Software Initiator

---

Before installing the Microsoft iSCSI Initiator for Windows, be sure the sever meets the requirements described in *Windows Server Requirements*. You must be logged in as an administrator to install the Microsoft iSCSI Software Initiator.

To install the Microsoft iSCSI Initiator on a server, follow these steps:

1. Obtain the latest Microsoft iSCSI Software Initiator from the following Microsoft download website and copy it to the server.

<http://www.microsoft.com/downloads/details.aspx?FamilyID=12cb3c1a-15d6-4585-b385-befd1319f825&DisplayLang=en>

There are different kits available. Choose the one that fits your server architecture. The following kits will install only on a retail build of Windows:

- iSCSI-2.0-ia64chk.exe - Checked (debug) version for computers based on the ia64 processor architecture.
  - iSCSI-2.0-ia64fre.exe - Retail version for computers based on the ia64 processor architecture.
  - iSCSI-2.0-x86chk.exe - Checked (debug) version for computers based on the x86 processor architecture.
  - iSCSI-2.0-x86fre.exe - Retail version for computers based on the x86 processor architecture.
  - iSCSI-2.0-amd64chk.exe - Checked (debug) version for computers based on the x64 processor architecture.
  - iSCSI-2.0-amd64fre.exe - Retail version for computers based on the x64 processor architecture.
2. Run the installation kit executable by entering the kit name on the command line or double-clicking the kit's file icon from a Windows Explorer window. The InstallShield Wizard appears. Click **Next** to continue.

**Figure 9: Microsoft iSCSI Software Initiator Installation - Start**



3. In the Installation Options dialog box, select the desired installation options.
  - **Virtual Port Driver.** Required for all installations. This option cannot be de-selected.
  - **Initiator Service.** Windows service that the initiator will use to interact with the operating system. This option *must* be selected, regardless of whether you are using a NIC or an iSCSI HBA.
  - **Software Initiator.** Driver for connecting to iSCSI devices through TCP/IP using network interface controllers. De-select this option if you are using an iSCSI HBA.
  - **Microsoft MPIO Multipathing Support for iSCSI.** This installs the core Microsoft MPIO files and the Microsoft iSCSI Device Specific Module (DSM). This will enable the Microsoft iSCSI Software Initiator or iSCSI HBA to perform session-based multipathing to a target that supports multiple sessions to a target. If the version of the MPIO core files is later than the version installed on the computer, the core MPIO files will be upgraded to the latest version that is part of the installation package. Microsoft MPIO is supported on Windows Server 2003 platforms and future Windows Server platforms. This option must be selected.

**Figure 10: Microsoft iSCSI Software Initiator – Installation Options**

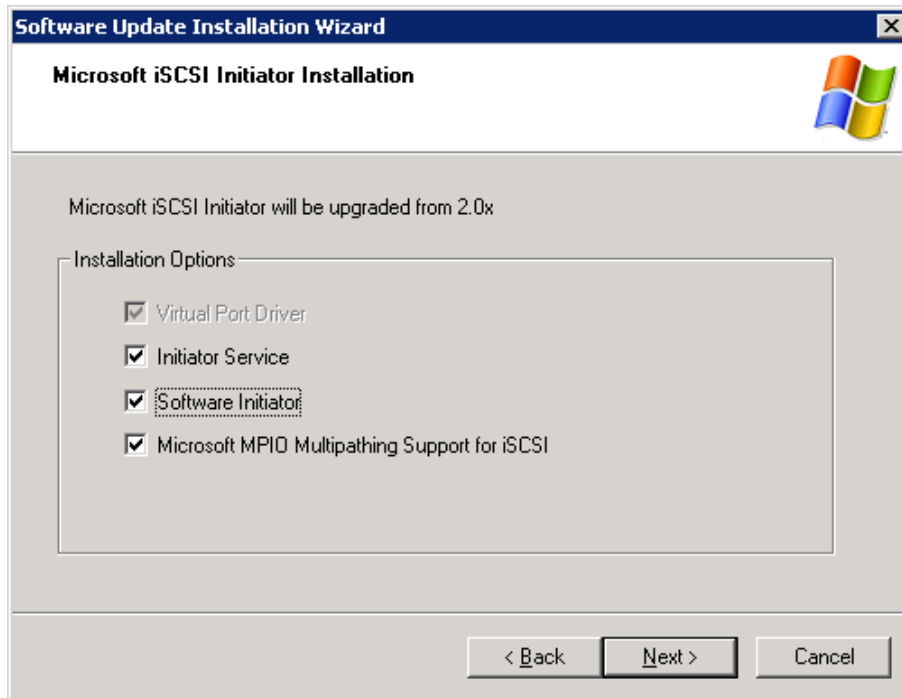

4. In the License Agreement dialog box, click the **I agree** button and then click **Next**.

**Figure 11: Microsoft iSCSI Software Initiator – License Agreement**

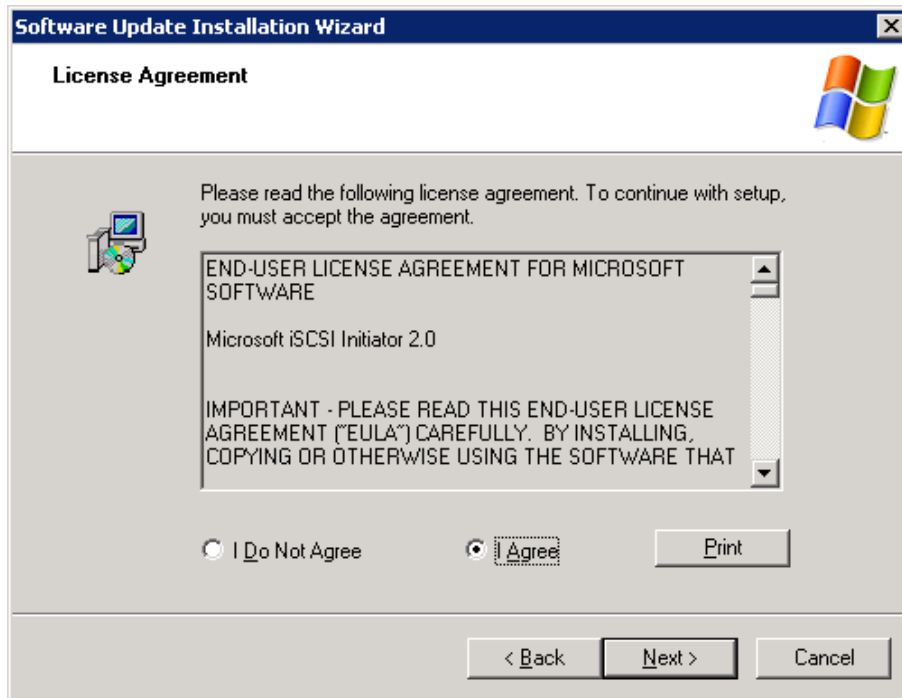

5. Once the installation is complete, click **Finish**. It is recommended that you reboot the system after the installation, although it is not required.

**Figure 12: Microsoft iSCSI Software Initiator - Finish**

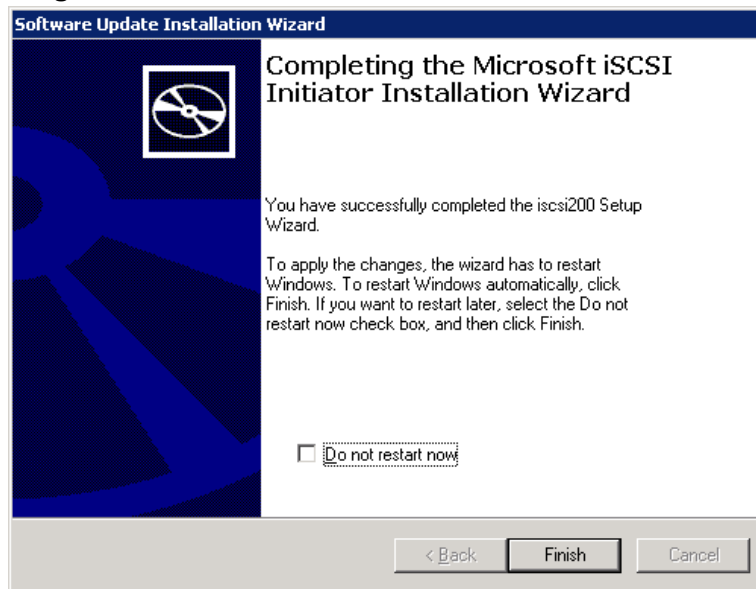

---

## Uninstalling the Microsoft iSCSI Software Initiator

To uninstall the Microsoft iSCSI Software Initiator, use the Add/Remove Programs tool in the Control Panel. Select Microsoft iSCSI Software Initiator and click **Remove**.

You may want to reboot the server after removing the software, although it is not required.

---

## Setting Up Multipathing

The following sections describe how to configure a redundant path between a server and PS Series storage. Be sure the iSCSI SAN is configured and volumes created, as described in *Setting Up the iSCSI SAN*, and the iSCSI initiator installed on the server.

---

### Configuring Multiple Paths to a Target

This section describes how to configure multiple paths from a server to an iSCSI target (PS Series volume). The server must have at least two NICs or HBAs configured to handle iSCSI traffic, and the volume's access control records must allow the server access through either NIC or HBA. In the example below, CHAP and IP addresses are used to authenticate initiator access to the volume. See *Restricting Access to Volumes* for more information about access control records.

**Note:** When logging in to a volume's target, be sure to establish a persistent connection to the target. You should also bind the target using the **Bound Volumes/Devices** tab to ensure that the volume will be available when the iSCSI service is started by Windows. If you have an application that uses drive letters (for example, SQL or Exchange), perform the bind after assigning a drive letter.

Follow these steps to configure multiple paths to a target:

1. Launch the Microsoft iSCSI initiator. Click **Start > Programs > Microsoft iSCSI Initiator > Microsoft iSCSI Initiator**. The iSCSI Initiator Properties dialog box appears.

**Figure 13: Microsoft iSCSI Initiator Properties**

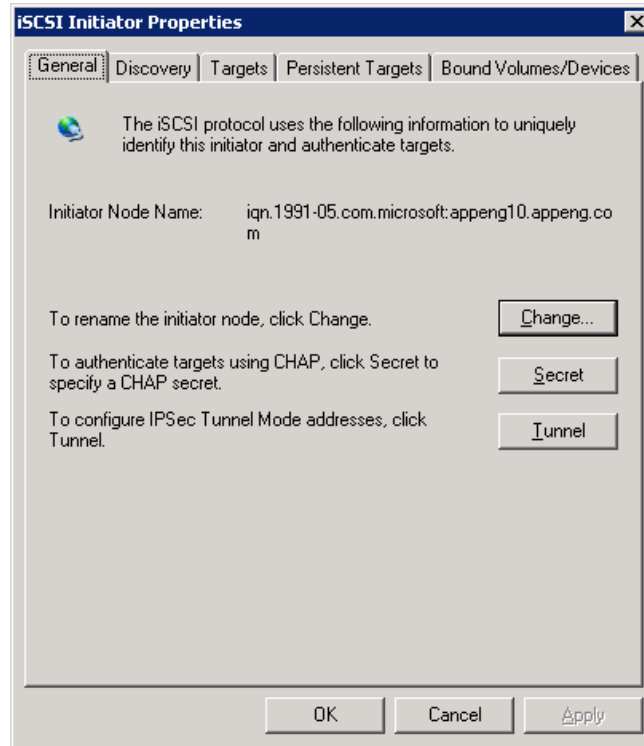

2. Discover the targets (volumes) presented by the PS Series group. Click the **Discovery** tab and then **Add**. Specify the IP address of the group and, optionally, the port. Then, click **OK**.

**Figure 14: Microsoft iSCSI Initiator Properties – Add Target Portal**

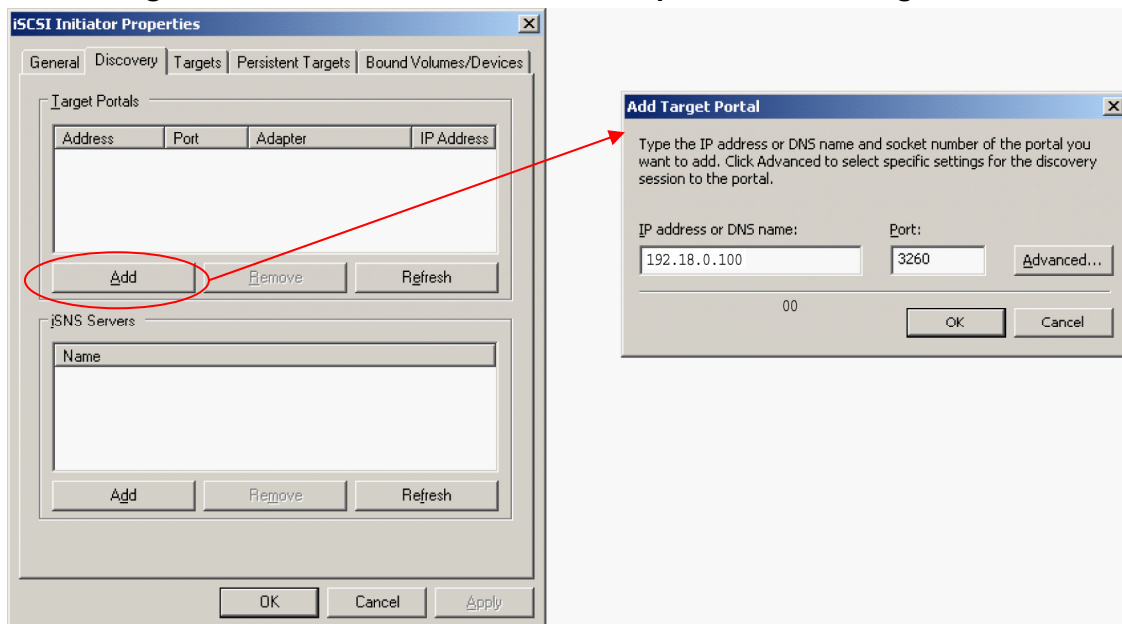

3. Click the **Targets** tab. The available targets (volumes) presented by the group appear with the status *inactive*. Note that the volume name is appended to the end of the target name.

**Figure 15: Microsoft iSCSI Initiator Properties – No Target Connection**

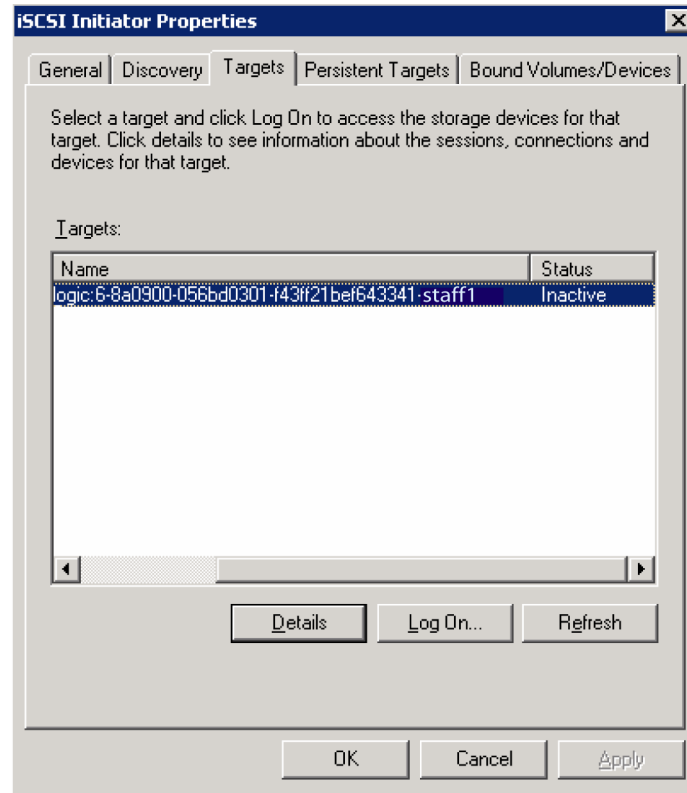

4. Select the target for the desired volume and click **Log On**. The Log On to Target dialog box appears. Select **Automatically restore this connection when the system reboots** (for a persistent connection across server reboots) and **Enable multi-path**. Then, click **Advanced**.

**Figure 16: Microsoft iSCSI Initiator Properties – Log On to Target**

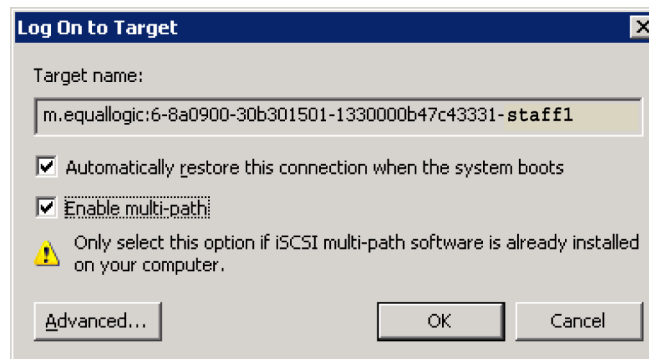

- In the Advanced Settings dialog box, specify the iSCSI initiator in the **Local Adapter** field and specify the IP address for one of the NICs or HBAs you are using for iSCSI traffic in the **Source IP** field. In the **Target Portal** field, specify the group IP address.

If the volume is protected by CHAP, check the box next to **CHAP logon information** and specify the user name and secret (password). To be able to log in, the CHAP information must match an access control record for the volume and also an entry in a CHAP database set up in the group or on an external RADIUS server.

**Figure 17: Microsoft iSCSI Initiator Properties – Advanced Settings**

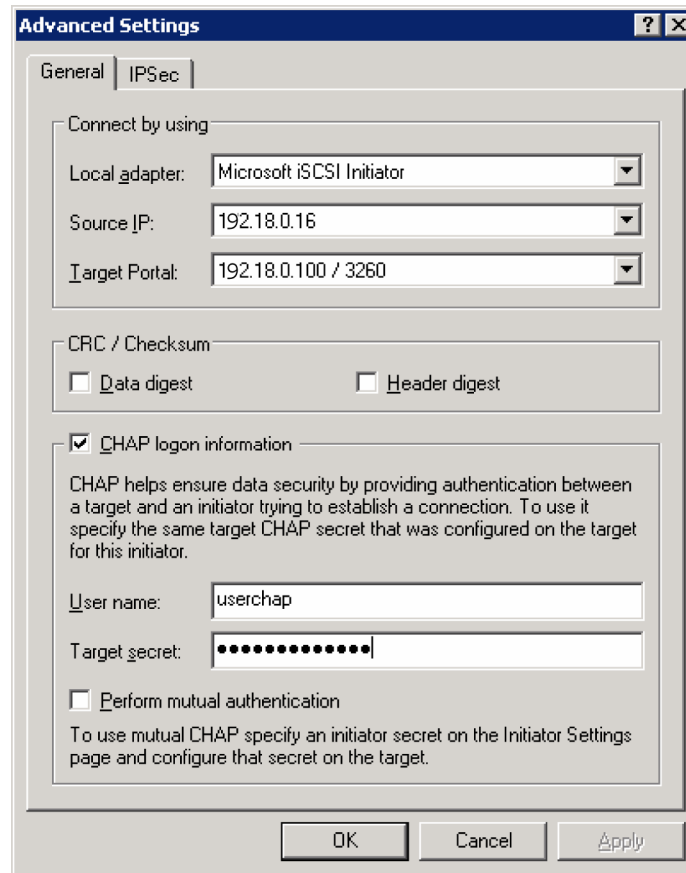

Click **OK** when you are finished. The Log on to Target dialog box appears again. Click **OK** to complete the logon.

In the Targets Tab dialog box, the status of the volume should now be *Connected*. This represents the first iSCSI connection path to the volume.

- To create a second path to the target, in the Targets Tab dialog box, select the target to which you just connected and click **Log On**. In the Log On to Target dialog box, click **Advanced**.

7. In the Advanced Settings dialog box, specify the same information as you specified in Step 5 above, except that you must specify the IP address for a *different* NIC or HBA that is being used for iSCSI traffic in the **Source IP** field.

**Figure 18: Microsoft iSCSI Initiator Properties – Second Path**

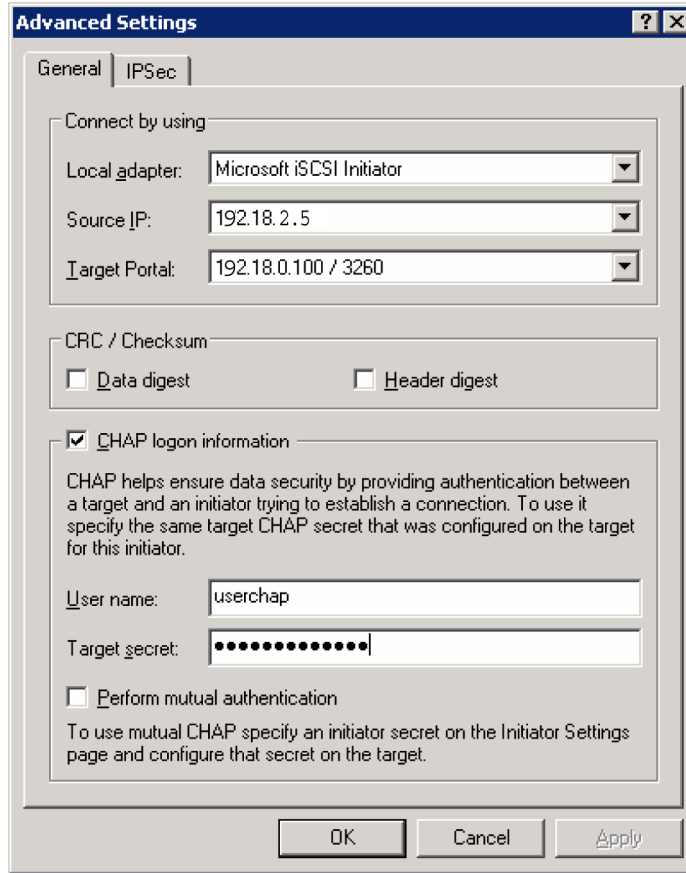

Click **OK** when you are finished. The Log on to Target dialog box appears again. Click **OK** to complete the second connection.

8. To confirm the second connection to the volume, in the Targets Tab dialog box, select the volume and click **Details** to display the Target Sessions dialog box. The two sessions to the volume should appear, as shown in Figure 19 below.

Also, Click the **Devices** tab to display the Target Devices dialog box. Verify that both entries in the MPIO Capable column specify **Multi-Path Support**, as shown in Figure 20 below. If not, the multipath configuration to the target was not successful.

Note that, by default, the MPIO load balancing policy is Fail Over Only. See *Modifying the Load Balancing Policy* for information about load balancing policies and how to modify them.

**Figure 19: Microsoft iSCSI Initiator Properties – Target Sessions**

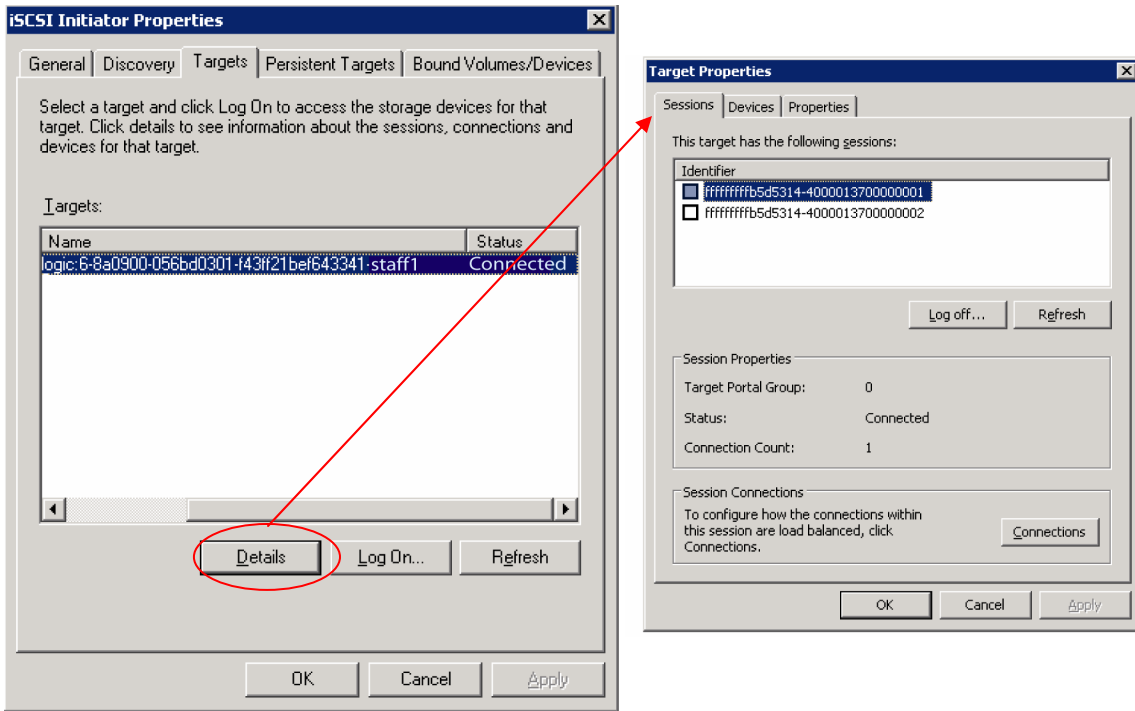

**Figure 20: Microsoft iSCSI Initiator Properties – Target Devices**

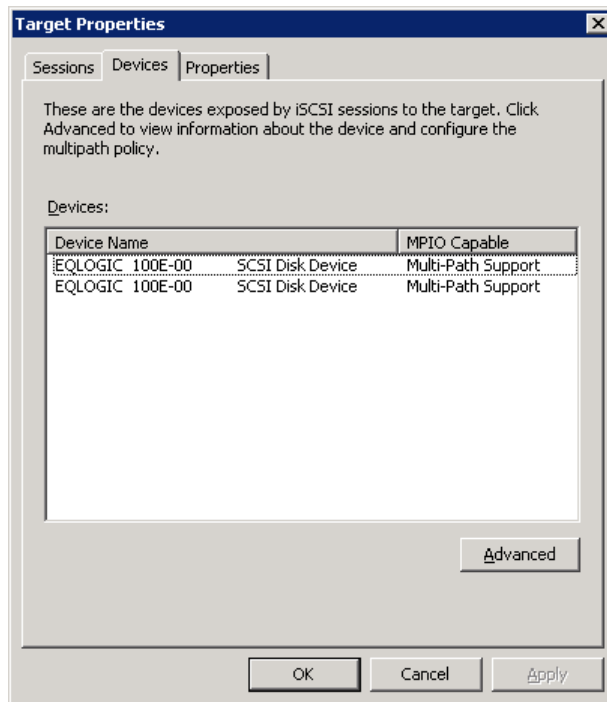

## Modifying the Load Balancing Policy

---

When multipath I/O is configured on two or more iSCSI interfaces, you can specify a load balancing policy the MPIO drivers will use for the interfaces.

The load balancing policies are available:

- **Fail Over Only.** The default load balancing policy, Fail Over Only means that one path is designated the primary path to which all I/O is directed and the other path is in standby mode. If a failure occurs, a non-primary path takes over and becomes active. This type of balancing is useful if one network path has better performance than the others. In this case, you can set the highest-performance network path as the primary path.
- **Round Robin.** This policy distributes I/O across all active paths using a round-robin technique. For example, if you have multipathing across three paths, I/O will be directed to the first path, then to the second path, then to the third path, before the process is repeated.
- **Round Robin with Subset.** This policy requires three or more multipath connections to a target. One set of paths is active, and the remaining paths are standby. I/O is distributed across the active paths using a round robin technique. If all the active paths fail, the standby paths become active. If a failed active path becomes available again, it will become active and any active standby paths will return to standby status.
- **Weighted Paths.** Weighted path load balancing allows you to assign a value to each multipath connection. I/O will be directed to the path with the lowest weight. If this path fails, the path with the next lowest weight will be used, and so on.
- **Least Queue Depth.** This policy is not supported by Microsoft for MPIO.
- **Least Blocks.** This policy is not supported by Microsoft for MPIO.

To modify the load balancing configuration for two paths to an iSCSI target, follow these steps:

1. Launch the Microsoft iSCSI initiator. Click **Start > Programs > Microsoft iSCSI Initiator > Microsoft iSCSI Initiator**. The iSCSI Initiator Properties dialog box appears.
2. Click the **Targets** tab. Select the target and click **Details**. The Target Sessions dialog box appears, displaying the two sessions to the target.

**Figure 21: Microsoft iSCSI Initiator Properties – Target Sessions**

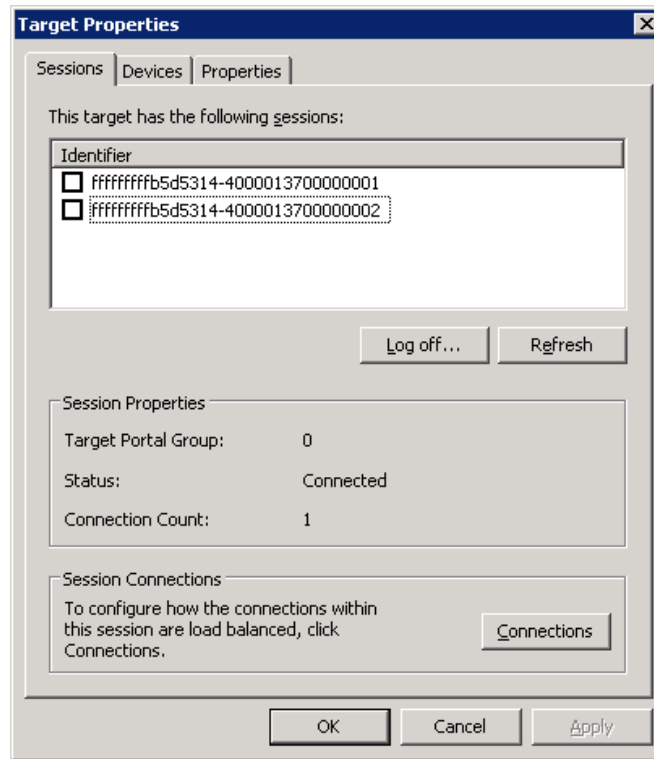

3. Click the **Devices** tab to display the Target Devices dialog box. Verify that both entries in the MPIO Capable column specify **Multi-Path Support**. If not, the multipath configuration to the target was not successful.

**Figure 22: Microsoft iSCSI Initiator Properties – Target Devices**

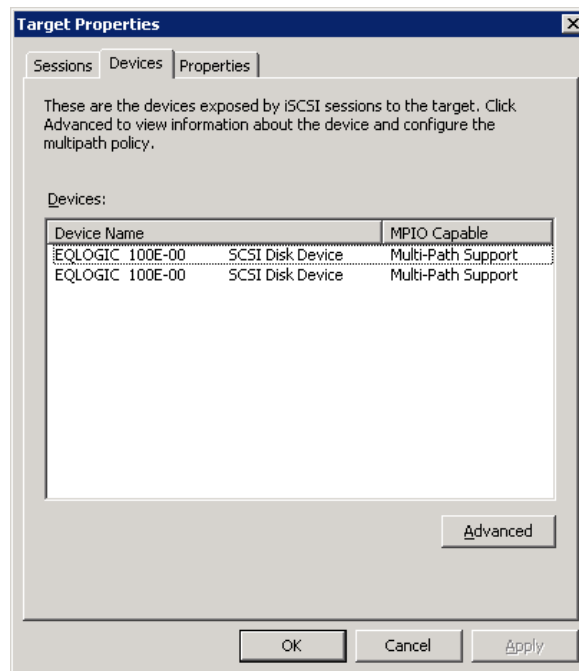

- Click the **Advanced** button and then click the **MPIO** tab to display the MPIO Device Details dialog box. This shows the current load balancing policy for the multipath configuration to the target and the status of each path.

The path ID represents a unique combination of host and target endpoints. Therefore, a connection to `eth0` and a connection to `eth1` on the same PS Series storage array will always have different IDs even if they use the same NIC or HBA.

**Figure 23: Microsoft iSCSI Initiator Properties – Device Details, Fail Over Only**

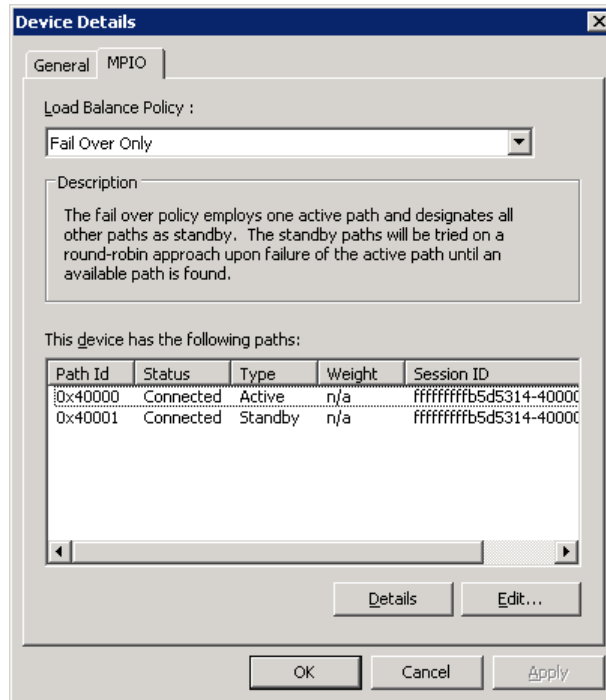

- Choose the desired policy from the **Load Balance Policy** list. Depending on your policy choice, you may need to perform additional tasks.

For example, if you specify **Weighted Paths**, you must apply a weight to each path. Specify 0 (the lowest weight) for the best-performing path. Select a Path Id and then click **Edit**. The Edit Settings dialog box appears, enabling you to specify the weight for the path. Figure 24 shows the weights assigned to two paths.

**Figure 24: Microsoft iSCSI Initiator Properties – Device Details, Weighted Paths**

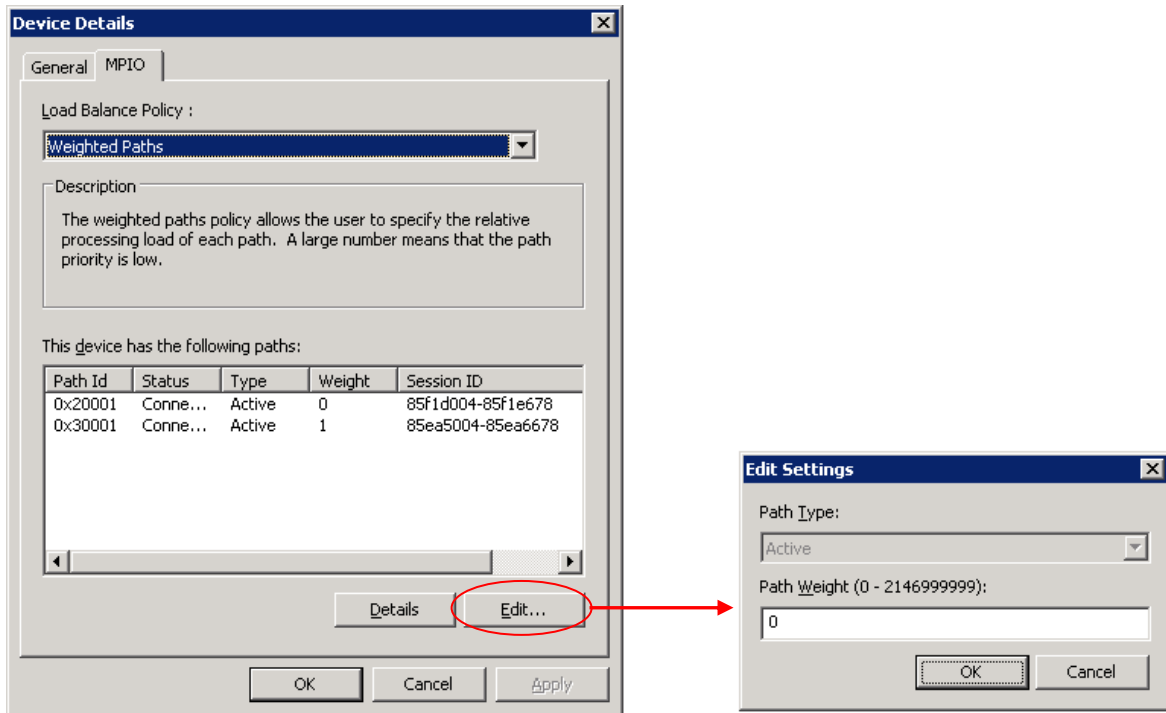

6. Once you specify the load balancing policy, click **OK** to close the Driver Details dialog box. Then, click **OK** to close the Target Devices dialog box.

## Displaying Path Information

To determine which iSCSI target (volume) is associated with a particular path, follow these steps:

1. Launch the Microsoft iSCSI initiator. Click **Start > Programs > Microsoft iSCSI Initiator > Microsoft iSCSI Initiator**. The iSCSI Initiator Properties dialog box appears.
2. Click the **Persistent Targets** tab, select a session, and click **Details**. The Persistent Target Details window appears, displaying the target name, as shown in Figure 25. Click **OK** to close the window.

**Figure 25: Microsoft iSCSI Initiator Properties – Persistent Target Details**

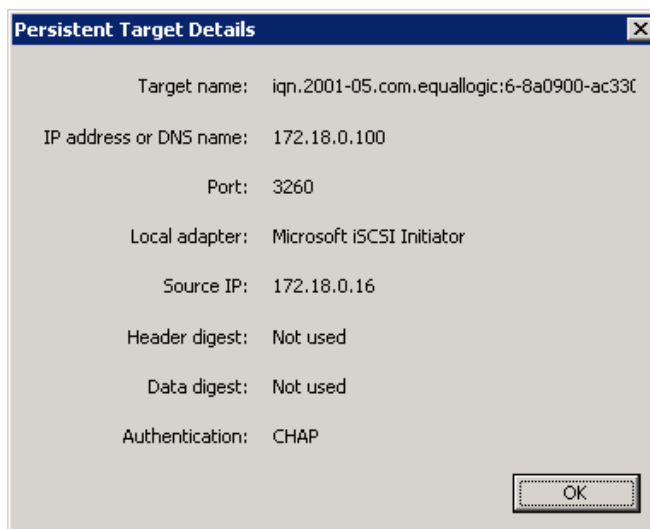

---

## Testing Multiple Paths to a Target

After enabling multipath access from a server to an iSCSI target (volume), test the accessibility of the target.

For example, if you have configured two paths to a target, establish an I/O load to the target. Then, disconnect the cable to one of the server's network interfaces that handles iSCSI traffic. Ensure that a connection to the target still exists. Then, reconnect the cable and disconnect the cable attached to the other network interface that handles iSCSI traffic. Ensure that a connection to the target still exists.

---

## Summary

You can use Microsoft multipath I/O (MPIO) to configure redundant network paths between Windows servers and highly-available, scalable PS Series storage arrays from EqualLogic. This is accomplished by having more than one physical path between the server and each storage array in the PS Series group.

Multipath I/O enables the server to detect network disruptions and fail over I/O to a functioning path in the event of a failure. It also provides robust load balancing capabilities for a reliable, high-performance I/O path between Windows servers and PS Series storage.

## PS Series Documentation and Customer Support

---

Visit the EqualLogic Customer Support website ([www.equallogic.com](http://www.equallogic.com)), where you can download the latest documentation and firmware for PS Series storage arrays. You can also view FAQs, the Knowledge Base, and Technical Reports.

EqualLogic PS Series storage array documentation includes the following:

- *Release Notes*. Provides the latest information about PS Series storage arrays.
- *QuickStart*. Describes how to set up the hardware and start using PS Series storage arrays.
- *Group Administration*. Describes how to use the Group Manager GUI to manage a PS Series group. This manual provides comprehensive information about product concepts and procedures.
- *CLI Reference*. Describes how to use the Group Manager command line interface to manage a group and individual arrays.
- *Hardware Maintenance*. Provides information on maintaining the PS Series storage array hardware.

To access the Customer Support website, from the EqualLogic website, click `Support` and log in to a support account. If you do not have an account, create one by clicking the link under the login prompt.

To contact customer support, send e-mail to [support@equallogic.com](mailto:support@equallogic.com). If the issue is urgent, call 1-877-887-7337 to speak with a member of the customer support team. You can also submit a service request from the Customer Support website.